



Production guidelines for Australian table grape varieties

February 2002

AG0987

ISSN 1329-8062

Rosie Hannah (Irymple), Deidre Jaensch (Irymple) and Greg Moulds (NSW Agriculture)

This note includes a description of the most commonly grown table grape varieties in Australia, and includes production guidelines.

The production guidelines include techniques or problems specific to each variety and assume a good level of management, irrigation monitoring and a sound pest and disease control program.

General recommendations common to all varieties

Soils

Table grapes adapt to a wide range of soil types. But on rich fertile soils, vines may produce excessive vigour and must be managed to produce sweet and well-coloured fruit. Less fertile soils are often favoured for table grapes.

Row Orientation

The row orientation depends on the direction of the prevailing wind and the path of the sun. Rows that run in the same direction as the wind have a more uniform distribution in foliage. Rows that run East-West provide maximum protection from the hot afternoon sun, preventing sunburn of the berries.

Vine Spacing

Rows are generally 3.4 to 3.7m (10 to 11ft) apart. Vines within a row are generally spaced 2.4 to 2.7m (7 to 8ft) apart. Less vigorous vines, eg. Cornichon and Muscat Hamburg, may be spaced 1.5 to 1.8m apart.

Trellising

A grape trellis should:

- Facilitate even distribution of foliage to allow adequate light penetration for bud initiation and to aid pest and disease control.
- Improve conditions for fruit colouring (ie. greater interception of reflected light).
- Allow bunches to hang freely.
- Protect against sunburn.

The preferred trellis system is a 30° sloping “T” (Figure 1). The width of the trellis should be at least 1.2 metres

with 2 fruiting wires and 2 or more foliage wires. Vigorous vines may require trellis widths of up to 1.8 metres. The height of the trellis should be convenient to work with (approximately 1.5 to 1.7 metres).

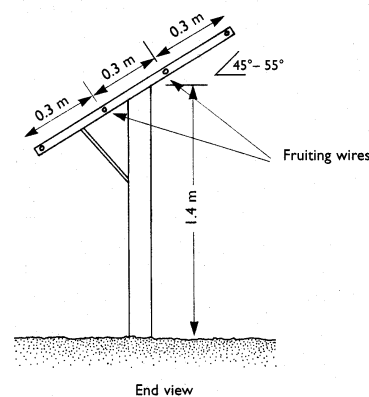

Figure 1 Sloping “T” trellis commonly used in Sunraysia

A “Y” trellis (Figure 2) to reduce canopy density and improve air circulation and light interception around bunches has been used with some vigorous varieties.

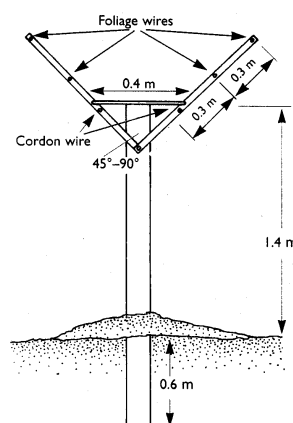

Figure 2 “Y” shaped trellis for more vigorous varieties

Nutrition

Table grapes in general require higher nutritional levels than those of wine grapes. Annual petiole analysis should be used to guide fertiliser use.

Irrigation

Table grapes must never suffer from a shortage or excess of soil moisture. Irrigations must be regulated so that the berry growth is uninterrupted. Too much water is likely to cause waterlogging and poor fruit quality. Monitoring of water use is essential.

Years to full production

For most varieties it will take 4-5 years for vines to reach full production. Small crops may be produced in the second year but avoid overcropping as the young vines need most of their reserves to develop a strong vine structure.

Definition of terms

Bunch tipping – removing the bunch tail.

Bunch thinning – removing undersized, poorly set or tangled bunches.

Berry thinning – removing individual berries in a bunch.

Shoot thinning – removing unwanted shoots (whole shoots).

Shoot topping – removing 100 mm or more from the shoot tip.

Shoot tipping – removing less than 100 mm from the shoot tip.

Girdling – removing a 3-6 mm ring of bark (down to the cambium) in a complete circle around the trunk or arms.

GA – Gibberellic Acid.

Blush Seedless**Description**

Blush seedless berries are red, oval and seedless. Berries may be uneven in size. The skin is tender and crisp with meaty flesh. Bunches are large, and well filled/compact, uniformly long, conical and symmetrical. Vines are vigorous.

Practices

Pruning: spur prune to 12-14 spurs per vine with 2 buds per spur. Thin shoots when they reach 200 mm in length. Only a few lateral shoots develop and these should be removed.

Crop thinning: after berry set remove unwanted bunches to the desired crop load.

Crop load: 25-30 bunches per vine.

Use of GA: unknown.

Rootstocks: generally avoid high vigour stocks.

Colouring: remove basal leaves and position canes at the first sign of colouring.

Maturity: minimum 16° brix.

Harvest period: begins in late February. Bunches remain on the vine for a long period.

Cool storage: 12-20 weeks.

Susceptibility to rain damage: unknown.

Susceptibility to sunburn: unknown.

Special notes: this variety is susceptible to powdery mildew and bunch rots if overcropped. May show Magnesium deficiency symptoms when heavily cropped.

Calmeria**Description**

Calmeria berries are pale green, large, cylindrical and seeded. They have a tough berry skin and fleshy pulp with a pleasant but neutral flavour. Bunches are large, conical and well filled. Vines are very vigorous.

Practices

Pruning: cane prune to 4-6 canes with 8-9 nodes per cane. If there is a history with overcropping, spur prune to 2 buds per spur.

Crop thinning: prior to flowering, remove bunches if required and trim the bottom half of the remaining bunches immediately after shatter.

Crop load: maximum of 30 bunches per vine.

Use of GA: not recommended.

Rootstocks: performs well on Ramsey.

Colouring: no treatments required.

Maturity: minimum 16° brix.

Harvest period: mid to late March – early May.

Susceptibility to rain damage: medium.

Susceptibility to sunburn: high.

Special notes: this variety is sensitive to moisture stress which may result in sunken bluish-brown thumbprints. Vineyard cooling with overhead sprinklers or overhead shade cloth during hot weather may reduce “thumbing”. Mealybugs may be a problem with this variety.

Ohanez**Description**

Ohanez berries are golden green, medium to large in size, cylindrical and seeded. The berry skin is thick and tough while the pulp is firm and fleshy with a neutral flavour. Bunches are medium in size, short conical and moderately compact. Vines are moderately vigorous.

Production techniques for Ohanez: see Calmeria.

Pollination of Ohanez: Ohanez require artificial pollination by either:

1. Rubbing bunches with a sprig of newly opened flowers from another pollen-producing variety which is in flower at the same time as Ohanez. Eg. Italia, Muscat Gordo Blanco or Black Malaga.
2. Hand spray each bunch every 2-3 days during flowering, with a pollen suspension prepared by vigorously agitating a flowering bunch in a bucket of water.
3. Interplanting Ohanez with pollinating varieties such as Muscat Gordo Blanco, Waltham Cross or Red Emperor. Plant one pollinator for every eight vines (Refer to Figure 3), or entire rows of the pollinator in every fourth row of the block.

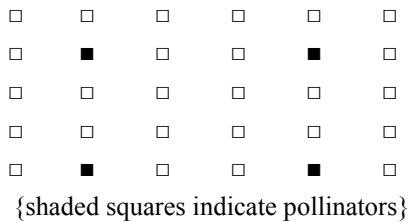

Figure 3. Guide for pollinator interplanting.

Cardinal

Description

Cardinal berries are reddish purple, large, round and seeded. They have soft skin, with firm juicy pulp and a distinctive flavour. Bunches are conical, large and loose (often straggly). Vines are vigorous.

Practices

Pruning: spur prune to approximately 28 spurs per vine, one bud per spur. Keep the centre of the vine clear and space the spurs evenly along the arm. Thin shoots to 2 shoots per spur when shoots are 200 mm long.

Crop thinning: before flowering, thin bunches to one bunch per shoot (usually the second bunch as this sets better than the first or third bunch), and remove the bottom half of the bunch to prevent straggleness. After berry set, bunches may be brushed by hand to remove undeveloped berries.

Crop load: maximum of 30 bunches per vine.

Use of GA: not recommended.

Rootstocks: avoid high vigour stock (eg. Ramsey and Dog Ridge), as they may cause poor colour and berry set. However, Ramsey may be suitable for this variety on infertile sandy soil. Incompatibilities with Schwarzmann and 34EM have been reported.

Colouring: ethephon sprayed at colour change may enhance colour.

Maturity: minimum of 15° brix. Berries have low acid levels.

Harvest period: early January - early February.

Cool storage: not recommended.

Susceptibility to rain damage: high.

Susceptibility to sunburn: nil.

Special notes: because of their earliness this variety is very susceptible to bird damage. This variety is susceptible to Zinc deficiency and may have poor fruit set. To improve set, maintain a leafy canopy. Foliar sprays may be applied before flowering. This variety is also prone to "hen and chicken". Light and sandy soils are most suitable for this variety. Vine spacings of 2.4 to 2.7m have been used successfully.

Centennial Seedless

Description

Centennial Seedless berries are green amber, small to medium in size, and seedless. Their skin is thin and crisp, and the pulp firm with a muscat flavour. Bunches are loose and well filled. Vines are vigorous with moderate yield.

Practices

Pruning: prune to 12- 14 spurs with 2 or 3 buds per spur. Shoot thinning is not required as generally only 2 shoots develop per spur.

Crop thinning: bunch thinning is generally not required as only one bunch develops per shoot. Trim bunches hard leaving the top third of the bunch.

Crop load: 25 bunches per vine.

Use of GA: not recommended.

Rootstocks: Centennial is very vigorous on own roots.

Colouring: no treatment required.

Maturity: minimum 16° Brix.

Harvest period: begins in mid-late January and continues to early February.

Cool storage: not stored.

Susceptibility to rain damage: low.

Susceptibility to sunburn: does not burn but may develop brown marks after berry softening (veraison).

Special notes: berries brown easily on the vine and during transport to markets, making this variety less desirable for commercial marketing.

Christmas Rose

Description

Christmas Rose berries are a strong red colour. They are tear shaped and seeded, with large but uneven berries. Berries are larger and more even in size than Emperor. Berries are crisp with a thin, tender skin and a neutral flavour. Bunches may be very large, conical and loose. Vines are vigorous.

Practices

Pruning: spur prune to 12-14 spurs per vine with 2 buds per spur. Shoot thinning is not required.

Crop thinning: bunch thinning is not required as only one bunch develops per shoot in general. Trim bunches to leave only the top 3 shoulders.

Crop load: 25-35 bunches per vine.

Use of GA: not recommended.

Rootstocks: will perform well on medium vigour stocks.

Colouring: this variety is not dependent on light for colouring. Therefore no leaf pulling or cane positioning is required.

Maturity: minimum 16° to 18° brix.

Harvest period: begins in mid to late March.

Cool storage: stores well.

Susceptibility to rain damage: moderately resistant.

Susceptibility to sunburn: nil.

Special notes: berries have a waxy bloom and are quite attractive after trail shipments. Centennial Seedless produces a significant second crop of good quality (medium sized berries) in late April – around 20-25% of the first crop. This variety is very susceptible to powdery mildew.

Crimson Seedless

Description

Crimson Seedless berries are bright red, large, cylindrical-oval and seedless. They have thick, tough skin, and firm crisp flesh with a neutral flavour. Bunches are medium in size, conical with a shoulder, and well filled to slightly compact. Vines are very vigorous.

Practices

Pruning: cane prune to 6 – 10 canes per vine, each with around 15 buds per cane. Leave 6 spurs, with 2 - 3 buds per spur for replacement canes.

Crop thinning: after fruit set, trim bunches to 5 – 6 sprigs per bunch. Berries and / or shoulders should be removed from the compact regions of well-set clusters to reduce tightness.

Crop load: do not exceed 18 bunches per vine in the first year of production. Mature vines should not exceed 35 bunches per vine.

Use of GA: GA sprays are not recommended. GA increases berry shatter and reduces berry colouring, budburst, and vine fruitfulness in the following season.

Rootstocks: Crimson Seedless vines are highly vigorous on their own roots. If a rootstock is required, use one with low vigour.

Colouring: at colour change, remove basal leaves from around bunches. Shoot thinning or hedging, at berry softening may also improve light interception by bunches.

Maturity: 20: 1 sugar/ acid ratio.

Harvest period: early March to late April.

Cool storage: 12- 20 weeks.

Susceptibility to rain damage: low.

Susceptibility to sunburn: medium to low.

Special notes: girdling at berry set may be used to increase berry weight and size. This variety is highly susceptible to mildew and Botrytis infection. Hen and chicken may be a problem.

Dawn Seedless

Description

Dawn Seedless berries are golden, medium in size, oval and seedless. Berries have tough skin, which is difficult to chew, and a firm meaty flesh. Bunches are short, conical to pyramidal, very uniform and well-filled to slightly compact. Vines have low to medium vigour.

Practices

Pruning: spur prune to 12- 14 spurs per vine with 2 buds per spur. Shoot thin to 2 shoots per spur when shoots are 200 mm.

Crop thinning: generally not required.

Crop load: 28 – 35 bunches per vine.

Use of GA: not recommended as GA spray produces small shot berries with some end splitting.

Rootstocks: unknown.

Colouring: not required.

Maturity: palatable at low sugar contents.

Harvest period: begins in mid-late January. Fruit break down rapidly after maturation.

Cool storage: unknown.

Susceptibility to rain damage: low.

Susceptibility to sunburn: nil.

Special notes: girdling is not recommended for this variety as the increase in berry size may result in more bunch rots. This variety is suitable for drying.

Emperor

Description

Emperor berries are red, medium sized, egg shaped and seeded. They have thick, tough skins and fleshy pulp with a pleasant but neutral flavour. Bunches are large, long, conical and well filled. Vines are very vigorous.

Practices

Pruning: cane prune to 8-10 canes with 10 nodes per cane for each vine depending on vigour. Spur pruning may also be done with 4 buds per spur as the first 2 buds don't have fruit.

Crop thinning: at flowering trim the bottom third to half of the bunch and remove bunches if required.

Crop load: do not retain more than 18 bunches per vine in the first year of production. Mature vines may carry 35 -40 bunches.

Use of GA: not recommended.

Rootstocks: Schwarzmann, 140 Ruggeri and Kober 5BB (Teleki 5A) have been used successfully. Incompatibility has been reported for 101-14.

Colouring: at the first sign of colour, remove basal leaves and trim canes to expose bunches to direct or reflected light. Ethephon may improve colour but should not be used on fruit destined for long-term cool storage as it may soften berries.

Maturity: minimum 16° brix.

Harvest period: mid March – mid May.

Cool storage: 12 -20 weeks (up to 6 months).

Susceptibility to rain damage: resistant.

Susceptibility to sunburn: low.

Special notes: may have problems with Botrytis, powdery mildew and hen and chicken.

Fantasy Seedless

Description

Fantasy Seedless berries are bluish-black, large, oval and seedless. They have tender skin and meaty pulp with a sweet neutral flavour. Bunches are medium, conical and loose (sometimes straggly). Vines are highly vigorous with low bud fruitfulness.

Practices

Pruning: cane prune to 6-8 canes per vine with 10-14 buds per cane. Leave 2-4 spurs for replacement canes.

Crop thinning: usually bunch thinning or trimming is not required due to the low bud fruitfulness. After fruitset trim bunches to the top 6-7 sprigs.

Crop load: do not retain more than 18 bunches per vine in the first year of production. Mature vines may carry 35-40 bunches.

Use of GA: do not use GA as it causes poor berry set and poor cropping for the following year.

Rootstocks: use low vigour rootstocks.

Colouring: girdling at the first sign of colour may produce more uniform colouring and enhance maturity.

Maturity: 17.9:1 sugar / acid ratio.

Harvest period: mid January to mid March. Berries don't stay on the vine for longer than 2 weeks after they reach maturity.

Cool storage: up to 8 weeks.

Susceptibility to rain damage: high.

Susceptibility to sunburn: medium.

Special notes: girdling may enlarge berry size and can also reduce vine vigour. This variety has poor fruit setting characteristics and some flowering bunches may dry and drop from the vine. This variety is best suited to sandy soils. Market acceptance is good due to its berry size, seedlessness, colour and flavour.

Flame Seedless

Description

Flame Seedless berries are bright red, large to medium in size, round and seedless. They have crisp skin, and firm but juicy pulp, with a distinctive flavour. Bunches are medium to large, conical and well filled. Vines are vigorous.

Practices

Pruning: spur prune to approximately 20-24 spurs per vine, two buds per spur (bud number will depend on previous crop loads and vine vigour). Thin shoots to 2 buds per spur when shoots are 200 mm long.

Crop thinning: before flowering, thin bunches to one bunch per shoot. Within four weeks of fruit set and after the last GA spray, trim bunches to 4-6 shoulder sprigs.

Crop load: 20 (younger vines) – 30 (established vines) bunches per vine depending on vine vigour.

Use of GA:

2 thinning sprays (**WA only**):

- 3-5 ppm GA when 40-50% of bunches reach full bloom
- 3-5 ppm GA when 80-90% of bunches reach full bloom

2 Sizing Sprays (**WA only**):

- 20-35 ppm GA when 50% of bunches are between 5-8 in berry size (berry shatter may not be complete).
- 20-35 ppm GA when 100% of bunches are between 5-8 in berry size (berry shatter may not be complete).

Rootstocks: Flame Seedless vines perform well on their own roots in nematode free soils. Ramsey is not recommended as it reduces colour development and berry set. Harmony may increase the number of shot berries. Freedom, 1103 Paulsen, K51-32, 140 Ruggeri, and Teleki 5A have been used. No incompatibilities known.

Colouring: cane trim and leaf pull at colour change to expose bunches. A single ethephon spray, at half colour, may aid colour development. Follow the spray application with an irrigation to prevent vine stress and fruit drop. Too much ethephon reduces the cool storage period and may damage (or brown) bunch stems. Over cropping and high rates of GA will greatly reduce the amount of colour production. Girdling at ripening may improve colour development.

Maturity: minimum 16° brix.

Harvest period: early - late January.

Cool storage: 8-10 weeks. Bunches transport well.

Susceptibility to rain damage: slight to moderate.

Susceptibility to sunburn: low.

Special notes: Nil.

Italia

Description

Italia berries are golden, large, oval and seeded. The skin is firm, and the pulp fleshy, with a mild muscat flavour when ripe. Bunches are medium to large, conical and well filled. Vines are vigorous.

Practices

Pruning: spur prune to 10-16 spurs per vine with 2 clear buds per spur. Remove unfruitful shoots.

Crop thinning: little to no thinning is required with one or two well set bunches being produced each shoot. Trim the bottom half of the bunch after shatter.

Crop load: maximum of 30 bunches per vine.

Use of GA: not recommended.

Rootstocks: avoid using Ramsey rootstocks as there is a general incompatibility with Muscat varieties and Ramsey.

Colouring: at veraison removal basal three or four leaves to improve colouring.

Susceptibility to rain damage: moderate.

Susceptibility to sunburn: low.

Special notes: berry skins bruise easily through leaf or stem, berry handling and loose packing. Not a good export variety. Suitable vine spacings are 2.4 to 2.7m.

Marroo Seedless

Description

Marroo Seedless berries are black, medium, short elliptic and seedless. They have a crisp skin and pleasant taste. Bunches are large conical and moderately loose. The vine has good vigour and yield.

Practices

Pruning: spur prune to 24-28 spurs, with two buds per spur.

Crop thinning: before flowering thin to one bunch per shoot and after fruit set, trim lower half of each bunch.

Crop load: maximum of 30 bunches per vine.

Use of GA: do not use GA as it may cause excessive berry drop and produce straggly bunches (or no bunches) in the following season.

Rootstocks: incompatibility has been reported for Teleki 5A. Other rootstocks, 1103 Paulsen, Freedom, Harmony and Kober 5BB, have been used successfully.

Colouring: not required.

Maturity: minimum 16° brix.

Harvest period: late January to late February.

Cool storage: unknown.

Susceptibility to rain damage: slight.

Susceptibility to sunburn: low.

Special notes: this variety is susceptible to Powdery Mildew infection. Bunches must be picked within 7-10 days from maturity as the berries soften quickly on the vine.

Muscat Hamburg

Description

Muscat-Hamburg berries are blue-black, medium to large, oval shaped and seeded. They have a firm berry skin, soft and juicy pulp with a strong Muscat flavour. The bunches are medium to large, conical and well filled. Vines are less vigorous and extremely fruitful.

Practices

Pruning: spur prune to approximately 24-28 spurs per vine, with one or two nodes per spur.

Crop thinning: after flowering, remove all but the first or second bunch per shoot. Bunches may be trimmed to improve quality.

Crop load: maximum of 30 bunches per vine.

Use of GA: not recommended.

Rootstocks: Incompatibilities have been reported for Ramsey and 101-14 rootstocks.

Colouring: colour may be improved by spraying with ethephon and removing leaves and canes at colour change. However, it is not usually required.

Maturity: minimum 16° brix.

Harvest period: mid January – mid March.

Cool storage: 4-6 weeks.

Susceptibility to rain damage: tolerant.

Susceptibility to sunburn: low.

Special notes: suitable vine spacing is 1.5 to 1.8m.

Perlette

Description

Perlette berries are golden yellow, small to medium in size, round and seedless. They have firm skin, soft and juicy pulp and a mild muscat flavour. The bunches are large shouldered, conical and compact (sometimes too compact). Vines are extremely vigorous.

Practices

Pruning: spur prune to 24-28 spurs, 2 clear buds per spur. Keep centre clear and evenly space spurs along arms. Cane pruning, followed by heavy bunch thinning, may produce looser bunches.

Crop thinning: just before flowering, bunches should be flower thinned (by up to 70%) to reduce compactness. Bunch thin two weeks after fruitset (one bunch per shoot). Trim remaining bunches to 3-4 shoulder sprigs. Bunches may be combed after berry set to reduce bunch compactness.

Crop load: 30-35 bunches per vine.

Use of GA: thinning sprays are not recommended as Perlette does not respond well.

One sizing spray (**WA only**):

- 40ppm GA when 100% of bunches reach full bloom.

Rootstocks: avoid rootstocks with high vigour eg. Ramsey and Dog Ridge. No incompatibilities known.

Colouring: not required.

Maturity: minimum 16° brix.

Harvest period: early January - early February.

Cool storage: not recommended.

Susceptibility to rain damage: extremely high.

Susceptibility to sunburn: low.

Special notes: Perlette is suited to light and sandy soils. Vines are susceptible to nematodes and bunch rots may cause problems if thinning is inadequate. Do not apply a sizing spray if bunches are already compact.

Purple Cornichon

Description

Purple Cornichon berries are purple, very large, olive shaped and seeded. They have thick skin and soft, fleshy pulp with a neutral flavour. Bunches are medium large, conical and well filled to compact. Vines are of medium vigour.

Practices

Pruning: spur prune to 2 buds per spur. Yield may be improved with 6-8 node canes.

Crop thinning: after flowering remove the tip of the bunches. Bunch thinning is not usually required as shoots usually only carry one bunch.

Crop load: 30 bunches per vine.

Use of GA: not recommended.

Rootstocks: unknown.

Colouring: unknown.

Maturity: minimum 16° brix.

Harvest period: late February – late April.

Cool storage: 6-12 weeks, travels well.

Susceptibility to rain damage: tolerant.

Susceptibility to sunburn: highly susceptible.

Special notes: most Australian clones are infected with leaf roll virus. Maintain balanced cropping levels and keep the soil moist during flowering and fruit set to reduce the number of watery berries (berries which are pale in colour and soft to touch) that develop.

Red Globe

Description

Red Globe berries are pinkish-red, very large, round and seeded. They have crisp skin, fleshy pulp, and a neutral flavour. Bunches are large, conical and well filled. Vines have low vigour.

Practices

Pruning: cane pruning to 4-6 canes per vine. No shoot thinning is required as usually only one bunch develops per shoot. Alternatively, spur prune with canes replacing weak arms if the spurs are too weak.

Crop thinning: Thin 2 weeks before flowering. At fruit set tail bunches to 3-4 laterals to get small bunches with large berries. Conduct bunch trimming when berry size is 6mm.

Crop load: first crop, 8 bunches and second crop 16-20 bunches. Full crop maximum of 25-30 bunches, less for weak vines.

Use of GA: not recommended.

Rootstocks: incompatible with Teleki 5A. Ramsey and Schwarzmann have been used, with Ramsey giving poor colour but excellent berry size.

Colouring: shoot removal should not be done around the bunch region until 7-10 days after colour change. This will promote uniform colour development without burning the berries.

Maturity: minimum 15-17.5° brix.

Harvest period: early February – early April.

Cool storage: 4-5 weeks. Berries are susceptible to sulphur dioxide damage and bunch stems are prone to browning during storage.

Susceptibility to rain damage: tolerant

Susceptibility to sunburn: highly susceptible during September to early January. Shade cloth may be used to reduce the amount of sunburn. Thin off exposed clusters.

Special notes: Red Globe is highly susceptible to black spot. Regular sprays against black spot in spring are essential. Red Globe is susceptible to a condition known as berry rot, where berries collapse when light pressure is applied. Suitable vine spacings are around 3m to produce larger berries. Closer spacings may reduce vine vigour.

Ribier

Description

Ribier berries are black, large, round and seeded. They have crisp skin, soft, juicy pulp, with a neutral flavour. Bunches are medium in size, short, conical, and vary from loose to well filled. Vines are vigorous.

Practices

Pruning: spur prune to approximately 24-28 spurs per vine with one bud per spur. Thin shoots to 2 shoots per spur when shoots are 200 mm long.

Crop thinning: before flowering, remove all bunches other than the second bunch per shoot. Trim the tail or bottom third of the remaining bunches at the same time. Bunches can be brushed after berry set to remove undeveloped berries.

Crop load: 30 bunches per vine.

Use of GA: not recommended.

Rootstocks: R99, Teleki SA and Jacquez have been used successfully. Ramsey may result in Zinc deficiency and poor fruit set.

Colouring: remove three or four leaves around the bunch at colour change. Ethephon has no effect on colouring Ribier bunches.

Maturity: minimum 15° brix.

Harvest period: mid February to mid March.

Cool storage: 8-14 weeks.

Susceptibility to rain damage: sensitive to rain.

Susceptibility to sunburn: low.

Special notes: Ribier is susceptible to Zinc deficiency resulting in poor fruit set and straggly bunches. Zinc foliar sprays may be applied prior to flowering. Girdling can increase berry size but may reduce colour development.

Ruby Seedless

Description

Ruby Seedless berries are red, small to medium, oval and seedless. They have firm skin and firm, juicy pulp. Bunches are large conical and moderately compact. Vines are vigorous and highly fruitful.

Practices

Pruning: prune to 8-10 canes with 6-8 clear buds per cane.

Crop thinning: after fruit set, thin clusters to one bunch per shoot. At flowering, trim the remaining bunches back to 2-4 shoulder sprigs per bunch.

Crop load: 18-24 bunches per vine. More may be kept but berry size, colour and sugar levels can be reduced and may increase problems with bunch rots.

Use of GA: not recommended.

Rootstocks: incompatibilities unknown.

Colouring: Ruby Seedless may require leaf pulling at the start of colouring to improve air circulation and light penetration into the canopy. An application of ethephon may also improve colouring.

Maturity: minimum 16° brix.

Harvest period: early to mid February - late March.

Cool storage: 4-12 weeks

Susceptibility to rain damage: low.

Susceptibility to sunburn: nil.

Thompson Seedless (Sultana)

Description

Sultana berries are yellow-green, small to medium, oval and seedless. They have soft berry skin, and firm, juicy pulp with a pleasant grapy flavour. Bunches are large, conical and usually well filled. Vines are vigorous.

Practices

Pruning: cane prune according to vine vigour, usually 6-8 canes with 14 buds per cane for each vine. Avoid exceeding 8 canes.

Crop thinning: after flowering, thin bunches to one bunch (largest) per shoot. After fruit set, trim bunches back to three or four shoulder sprigs

Crop load: maximum of 30 bunches per vine.

Use of GA: GA can be used to thin and size berries (refer to label).

Rootstocks: Incompatibility has been reported with 5BB Kober. Moss Sultana (clone of Sultana) is reported to be incompatible with Schwarzmann.

Colouring: Leaf pulling and shoot trimming just after berry softening, exposing bunches to indirect or reflected light will tend to make berries more golden in colour. If green coloured fruit is desired do not leaf pull.

Maturity: minimum 18° brix.

Harvest period: mid to late January – mid March.

Cool storage: 6-10 weeks.

Susceptibility to rain damage: high.

Susceptibility to sunburn: medium.

Special notes: girdling (cincturing) after the last GA spray also increases berry size and reduces berry shatter. Only girdle healthy vigorous vines. Thompson Seedless vines are very susceptible to nitrate-induced bud necrosis. Suitable vine spacings are 2.4 to 2.7m.

Queen

Description

Queen berries are red, large, oval shaped and seeded. They have firm skin and firm, juicy pulp with a pleasant grapy

flavour. Bunches are conical and well filled. Vines are vigorous.

Practices

Pruning: spur prune to 1 bud per spur, leaving 24-28 spurs per vine. Thin shoots to 2 shoots per spur when shoots are 200 mm long.

Crop thinning: before flowering, thin to one bunch per shoot. Within one week of fruit set, trim the bottom third (1/3) of remaining bunches.

Crop load: maximum of 20 bunches per vine.

Use of GA: not recommended.

Rootstocks: incompatibilities unknown.

Colouring: at the first sign of colouring cane trim and remove leaves to expose bunches to reflected light.

Maturity: minimum 16° brix.

Harvest period: early February – late March.

Cool storage: 4-8 weeks.

Susceptibility to rain damage: highly susceptible.

Susceptibility to sunburn: unknown.

Special notes: this variety is easily over-cropped which may cause problems with colouring and berry sizing. High temperatures and water stress during sizing sprays may induce splitting.

Waltham Cross

Description

Waltham Cross berries are golden green, large, long, oval and seeded. They have firm berry skin and firm, juicy pulp with a very pleasant grapy flavour. Bunches are large conical to cylindrical and well filled. Vines are vigorous and productive.

Practices

Pruning: spur prune after budburst to 20-24 spurs per vine, 2 buds per spur (reduces hen and chicken). Complete pruning by mid October. To make pruning easier, remove unwanted canes in winter, leaving only the canes to be spurred after bud burst.

Crop thinning: before flowering, remove all but the basal bunch for each shoot. After shatter, trim the bottom half of the bunches.

Crop load: 20-30 bunches per vine. Avoid overcropping as this results in soft berries at maturity.

Use of GA: not recommended.

Rootstocks: good performance on Ramsey. Reported to be incompatible with 101-14.

Colouring: remove basal leaves from around the bunch near harvest to improve the golden colour.

Maturity: minimum 16° brix.

Harvest period: late January – early April, bunches don't keep well on the vine once mature.

Cool storage: 4-8 weeks.

Susceptibility to rain damage: slight.

Susceptibility to sunburn: low.

Special notes: where phomopsis is a problem, spray an appropriately registered chemical every 2 weeks from bud burst to flowering. Suitable vine spacings are 2.4 to 2.7m.

Reference

Coomb, B.G. and Dry, P.R. (eds) (1992) *Viticulture Vol 2 Practices*, Adelaide: Winetitles pp 279-301.

This publication may be of assistance to you but the State of Victoria and its employees do not guarantee that the publication is without flaw of any kind or is wholly appropriate for your particular purposes and therefore disclaims all liability for any error, loss or other consequence which may arise from you relying on any information in this publication.